

max TX™ SERIES TWISTED PAIR Model TX-TPR6A Format-A Passive Single-Pair Receiver

- Single Unbalanced or Balanced 10 kΩ Audio Output
- Output on Detachable Terminal Block or Phono Jack
- +4 dBu Balanced Output; -10 dBV Unbalanced Output
- Switch Selects which Pair (A, B or C) feeds the Output
- Signal and Power Pair Pass-Through to LOOP OUT Jack
- Passive Circuitry Does Not Require Power
- Galvanic Isolation Provided for Both Outputs
- Daisy-Chain with Additional Format-A Receivers



The TX-TPR6A is a single-pair audio receiving module compatible with RDL Format-A twisted pair products. It is built in the versatile Max-TX series enclosure. The durable adhesives provided with the TX-TPR6A permit permanent or removable mounting. The TX-TPR6A may be rack or surface mounted with optional TX™ series accessories.

APPLICATION: The TX-TPR6A is a single-pair audio receiving module compatible with RDL Format-A twisted pair products. A front-panel switch set during installation determines which of the three FORMAT-A pairs feeds the module output. The audio signal received from the selected pair of the RJ45 INPUT jack feeds the -10 dBV unbalanced RCA phono jack output and the +4 dBu balanced detachable terminal block output. A bridging transformer provides isolation between the twisted pair cable and the audio output.

The TX-TPR6A is a single-pair receiver, bridging the input signal from the cable pair set on the front-panel switch during installation. This module receives only one cable pair, therefore a LOOP OUT RJ45 jack is provided for connecting additional Format-A receivers. Two other single-pair receivers may be chained to the LOOP OUT jack, or a single two-pair receiver may be connected. In addition to completing the reception of signals from all three FORMAT-A pairs, additional receivers may be connected to the same twisted pair feed. The bridging input circuits used in all FORMAT-A twisted pair receivers allow connection of up to 10 receiver outputs for each cable pair. The possibility of multiple receiver locations adds enormous flexibility in the design of audio routing systems using RDL FORMAT-A products. All three audio pairs are fed through from the INPUT jack to the LOOP OUT jack.

The TX-TPR6A is a passive module that does not require power to operate. Power present on a cable connected to one RJ45 jack is passed through to the modules connected to the other RJ45 jack.

RDL FORMAT-A features superior audio performance that rivals or exceeds shielded wiring. Design simplicity, ease of installation, unsurpassed flexibility, automatic fused power, exceptional hum rejection, low noise, and low distortion provide designers and installers the optimum choice in economical twisted pair products.

max TX™ SERIES TWISTED PAIR

Model TX-TPR6A

Format-A Single-Pair Receiver

Installation/Operation



EN55103-1 E1-E5; EN55103-2 E1-E4
 Typical Performance reflects product at publication time exclusive of EMC data, if any, supplied with product. Specifications are subject to change without notice.

- STEP 1:** Set the **PAIR** selector so the module is receiving signal from the desired pair A, B or C of the Format-A cable.
- STEP 2:** Connect the **INPUT** twisted pair cable coming from Format-A senders or distributors.
- STEP 3:** Connect *either* the **UNBAL OUT** jack (-10 dBV) or the **BAL OUT** (+4 dBu) terminals to a high-impedance equipment input.
- STEP 4:** Connect the **LOOP OUT** twisted pair cable feeding additional Format-A receiver(s), if any, and mount the module

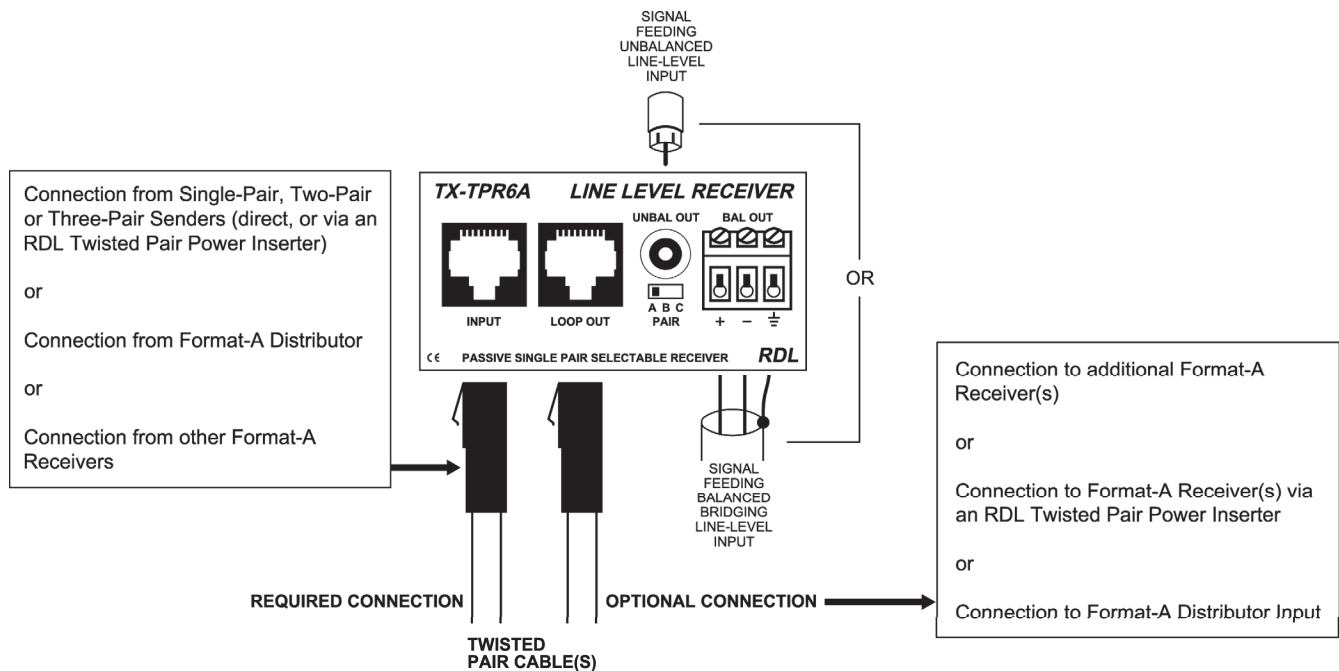

NOTE: This module is passive and does not use power. If power is present on either RJ45 jack, it is fed through to the other RJ45 jack. Therefore, the TPR6A can be connected together with powered Format-A modules.

RJ45 Standard wiring

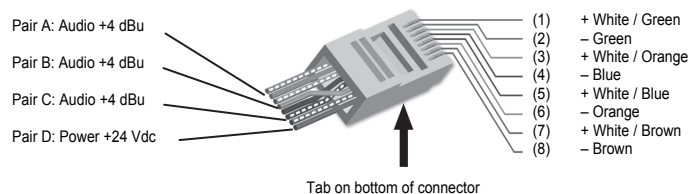

RJ45 conductor colors shown are for 568A standard. The 568B standard may be used if the connectors at both ends of the cable are wired identically.

TYPICAL PERFORMANCE

Input: RDL TP Format-A
 Input Connection: RJ45
 Format-A Signal Pair Used: Switch-selectable A, B, or C
 Format-A Output: RJ45 LOOP OUT
 Outputs (2): 10 kΩ Balanced; 3 kΩ Unbalanced
 Output Connection: Detachable Terminal Block (Bal); RCA (Unbal)
 Output Level: +4 dBu Bal., +22 dBu Max; -10 dBV Unbal.

Frequency Response: 20 Hz to 20 kHz (+/- 0.75 dB)
 THD+N: < 0.1% (1 kHz); < 0.5% (50 Hz to 20 kHz)
 Noise below +4 dBu: < 90 dB
 Headroom above +4 dBu: > 18 dB
 CMRR: > 90 dB (50 Hz to 150 Hz)
 Power Requirement: Passive
 Dimensions: 3.0" (7.6 cm) W; 1.6" (4.08 cm) H; 2.09" (5.3 cm) D